

# Pallet safety

Guidance Note PM15 (Fourth edition)

## Guidance Note Plant and Machinery

Guidance Notes are published under five subject headings:

General (GS)  
Medical (MS)  
Environmental Hygiene (EH)  
Chemical Safety (CS)  
**Plant and Machinery (PM)**

### Introduction

This guidance covers general-purpose flat pallets, which can be manufactured from a variety of materials. Pallets are used widely throughout industry, and this practical advice is for two audiences:

- those who have responsibilities for buying and using pallets as a base for assembling, storing, handling and transporting goods and loads;
- those who have responsibilities for the design and manufacture of pallets.

It tells buyers what they should ask designers and manufacturers to consider when designing a pallet. It also recommends how both new and used pallets should be used and inspected.

### Relevant legislation

The use of work equipment such as pallets is covered by the Provision and Use of Work Equipment Regulations 1998 (PUWER).<sup>1</sup> This includes a requirement for work equipment to be 'constructed or adapted as to be suitable for the purpose for which it is used or provided', as well as meeting maintenance and inspection requirements.

Your risk assessment, required by the Management of Health and Safety at Work Regulations 1999, should cover the hazards and risks from using and stacking pallets in the workplace. It should include not only the risks to employees but also any others at risk, for example members of the public or contractors visiting the workplace.

You can find more sources of information at the end of the guidance note.

### What is the legal definition of a pallet?

A pallet is defined in BS ISO 445 as follows:

'a horizontal platform of minimum height compatible with handling by pallet trucks, and/or forklift trucks and other appropriate handling equipment, used as a base for assembling, storing, handling and transporting goods and loads in factories, warehouses etc'.<sup>2</sup>

It may be constructed with, or fitted with, a superstructure.

## The accident record

Pallets are heavy, so when accidents occur they tend to be serious. Falling pallets have caused a number of fatal accidents but the risks posed by falling pallets are often not fully appreciated. Most accidents could be prevented by developing and following safe working practices.

Accidents directly attributable to pallets are usually caused by:

- poor design, construction or repair;
- using inferior materials;
- using a pallet which is unsuitable for a particular load, handling or storage method, eg pallets taken at random from a 'mixed bag' of used pallets for which the original specification is not known;
- unsafe stacking resulting in falling stacks or pallets;
- handling problems caused by mixing smaller Europallets (800 mm x 1200 mm) with larger UK pallets (1200 mm x 1000 mm) in racking systems. The smaller pallet may fall from the rack beams or be displaced by the larger pallet;
- continuing to use a damaged pallet;
- bad handling techniques;
- pallets being used in an unsuitable environment.

## Suitability

The majority of pallets are designed for moving a certain class or type of goods and are intended to be handled or stored in a particular way. For example:

- a pallet designed for transporting cartons of cornflakes with a forklift truck and stored singly in racking is unlikely to be suitable for goods such as cans of paint lifted by a bar sling or multiple stacking;
- a pallet designed specifically to carry evenly distributed loads, such as cartons of cornflakes or sheet paper, will not be strong enough to carry concentrated loads such as an electric motor of the same weight. The design parameters should ensure that a pallet is of adequate strength for the purpose intended, particularly if it is to be used with a variety of loads, handling and storage methods.

## Pallet design considerations

Most manufacturers produce basic pallet designs suitable for general duties.

However, user requirements can differ widely and these basic designs may not satisfy some customers' requirements. Good communications between the pallet manufacturer and user are essential to ensure the pallet construction is suitable for its intended use.

It is recommended that, where possible, the pallet design should satisfy the requirements of the appropriate British Standards (BS ISO 6780: 2003, BS EN ISO 8611-1:2012, BS EN ISO 8611-2:2012 and BS EN ISO 8611-3:2012).<sup>3-6</sup>

The designer needs to know the following information to make sure the pallet is suitable for its intended use:

## Pallet loads

- The type of loads to be carried, for example if they are solid, liquid, powder, packed in drums, sacks, cartons etc
- If the loads have any characteristics likely to damage the pallets, such as having corrosive properties
- The weight of the loads and how they are distributed on the pallet, ie evenly over the whole surface or concentrated at one point
- If there is a recommended way for the load to be placed on the pallet and the consequences if this is not followed
- The requirements for the safe transportation of the loads, ie if the surface friction between the pallet and the load is adequate or if additional restraint will be required

## Pallet environment

- Where the pallet will be used, for example in cold-store, outdoors, indoors, chemical works, or drying rooms
- If the pallet will be used in an environment which has high or low temperatures or high humidity

## Pallet movement

- If the pallet is to be moved by pallet truck, forklift truck, cranes with fork attachments, bar slings, or automated stacking equipment – also if any conveyors are to be used
- If two-way or four-way entry is needed
- If the pallets will be lifted under their baseboards, eg as in storage and retrieval machines

## Stacking loaded pallets – height and weight considerations

- When pallets are stacked, think about the load on the bottom pallet and the capacity of the baseboards of each pallet when it comes to spreading the load. This should ensure that the payload does not distort over time, making the stack unstable. Such distortion is called ‘creep deflection’
- This sort of distortion can take place with various payloads, such as the deflection of plastics, powder settling in bags and the weakening of cardboard boxes due to moisture

## Pallet racking

- The type of racking to be used, eg shelf, beam, or drive-in-racking and if pallet support bars are fitted
- Drive-in racking places considerable stress on a pallet if it is stored with the longest dimension across the rack span. The shortest dimension should therefore be used
- The dimension span between vertical beams of the drive-in-racking, as this must be compatible with the design of the pallet. Pallet support beams must be wide enough to support a pallet positioned off-centre and close to one side of the rack opening. See Figure 1 (on page 5) for details

## Pallet reuse

- If the pallets are to be non-returnable/disposable or if they are intended to be reusable ‘durable’ equipment

## Pallet transportation

- The dimensions of the vehicles or containers that will carry the pallets

## Pallet size

- Where possible, pallet sizes should follow those recommended in BS ISO 6780: 2003<sup>3</sup>

## Pallet management planning

Problems can be caused by a user selecting a pallet at random from a pallet store on the premises, without thinking of what it is being used for. Here are some recommendations to help you promote both effective and safe usage in your pallet management plan.

### Stability of the load

Pallets should be loaded to an established pattern designed to achieve maximum stability and safety within the rated load of the pallet. Loads should be applied gradually and, unless the pallet has been specifically designed for point loading, should as far as possible be uniformly distributed over the deck area.

### Height of the load

As a general guide, the height of the load should not exceed the longest base dimension of the pallet. Shrink- or stretchwrapping the load usually provides greater security, minimising the possibility of movement of the goods being moved. With these techniques you can safely transport loads taller than the longest base dimension of the pallet. This will result in palletised loads that are around the internal height of closed vehicles or freight containers.

### Plastic pallets

Plastic pallets have slippery surfaces and extra measures may be needed to secure the goods to them during transportation and to ensure that empty plastic pallet stacks are stable. Special attention is required when transporting plastic pallets by forklift truck as they are extremely slippery and potentially unstable on the forklift's tines.

If palletised loads are to be stacked directly on top of each other, provide a firm base on the floor and on top of the preceding pallet load.

### Deciding on a safe stacking height

When deciding on a safe stacking height, the pallet user should take into account:

- information from the pallet manufacturer – this is particularly important for plastic pallets. All safe loading information should use the terminology defined in BS EN ISO 445;<sup>2</sup>
- the support characteristics of the pallets payload – get information from the payload supplier where necessary;
- local conditions/stacking pattern.

Stacks should be checked periodically, as stability depends on the type and shape of the load and on prevailing humidity and temperature conditions.

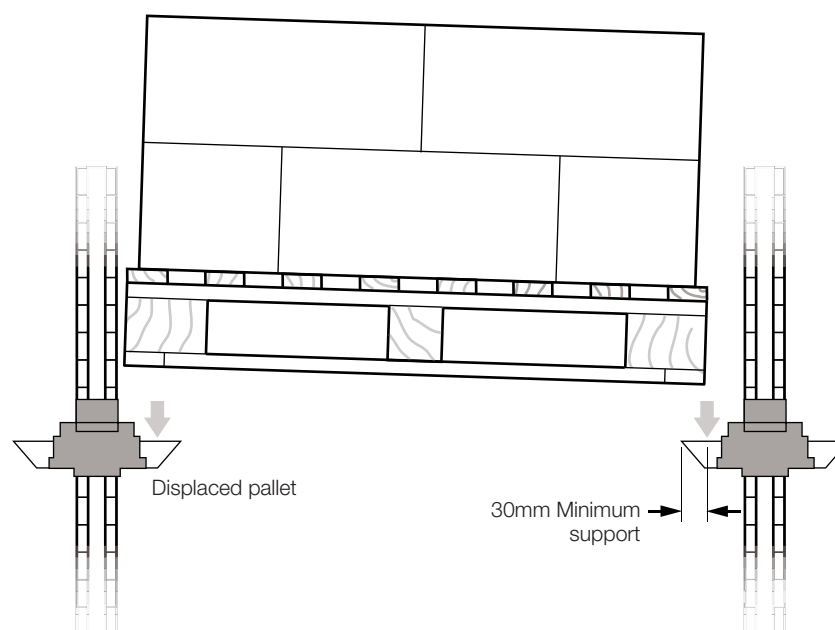
Stack height depends on the height, strength and stability of the unit loads, and the ability of the operator to see clearly. Only build taller stacks after detailed consultation with the manufacturer or other competent authority, and the maximum height should be no more than six times the narrowest dimension of the bottom pallet. This is provided that:

- you have carefully assessed the block stacking pattern and the compression characteristics of the payload;
- the pallet itself is designed to meet the stacking height required.

## The compression hazard

The use of pallets with racking (see Figure 1) can reduce the compression hazard to the load, but can cause additional stresses on the pallet. Loaded pallets should not be stored in racking unless they are suitably designed and constructed for the type of racking concerned.

When pallets are used in storage and retrieval warehouses, assess the additional dynamic stresses induced in pallet support members by high acceleration and deceleration forces.

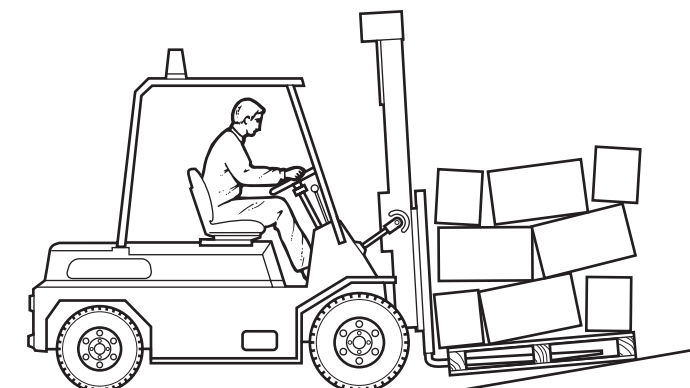


**Figure 1** Storage of pallets in racking. The span between the vertical beams of the drive-in-racking must be compatible with the design of pallet

## The handling layout

Assess the handling layout carefully to avoid tight corners, awkwardly placed doors, pillars and walls, uneven surfaces (see Figure 2), change of gradients etc. The use of a one-way traffic system and personnel guard rails should be considered for racking areas – see *Workplace transport safety: Guidance for employers* (HSG136).<sup>7</sup> When pallets are stacked in block formation, allow adequate clearances at the side and rear of each individual stack.

Establish an effective routine for pallet damage inspection and out-sorting. This should pay particular attention to structurally critical components. You should also provide training to promote safe methods of working.



**Figure 2** Ramps and uneven surfaces can cause loads to be jolted and bases of pallets to be damaged

## Pallet use and maintenance

Pallets should be examined for damage by the user on delivery. Damaged pallets should be marked accordingly, isolated and withdrawn for repair or disposal. Many pallets in the market belong to pallet pools and are marked with the trademark of the pallet owner or pallet organisation responsible for controlling their quality.

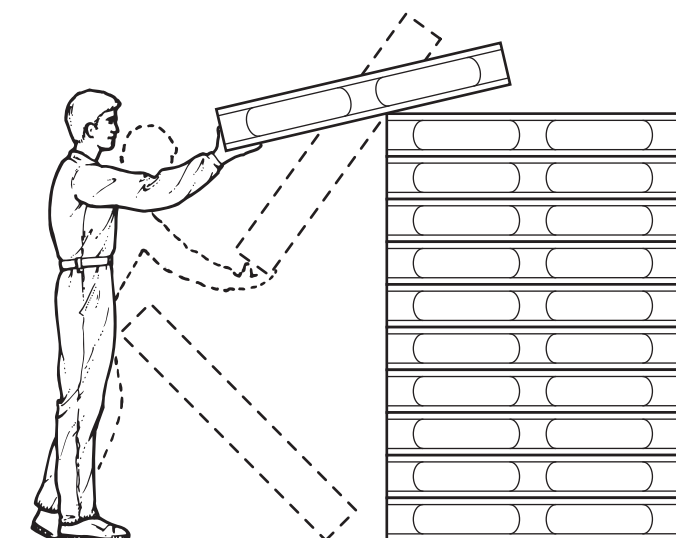
Such pallets needing repair should, in the first instance, be returned to the pallet owner or to the trademark owner's authorised representative. In the case where it is not possible to determine ownership or trademark responsibility, you can refer to BS EN ISO 18613 for general guidance.<sup>8</sup>

All pallets should be inspected every time they are used to ensure they are in a safe condition and fit for their intended purpose.

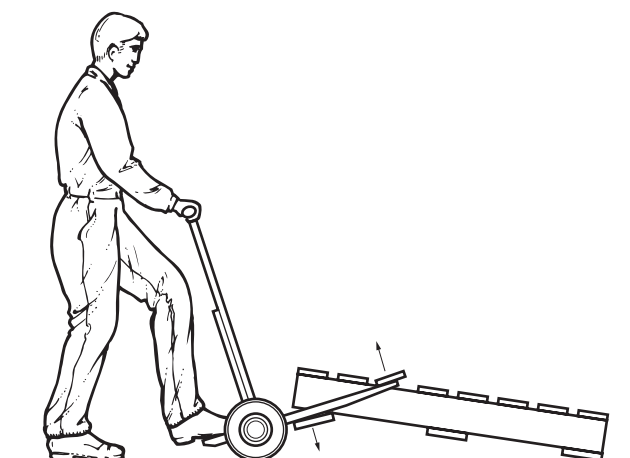
Disposable pallets, ie pallets designed for one delivery only, should be clearly marked as such. Be extremely careful if you are thinking of reusing them.

Empty pallets should be handled carefully and not dragged or thrown down (see Figure 3). They should not be handled by wedging the platform of a sack barrow between top and bottom deck boards (see Figure 4).

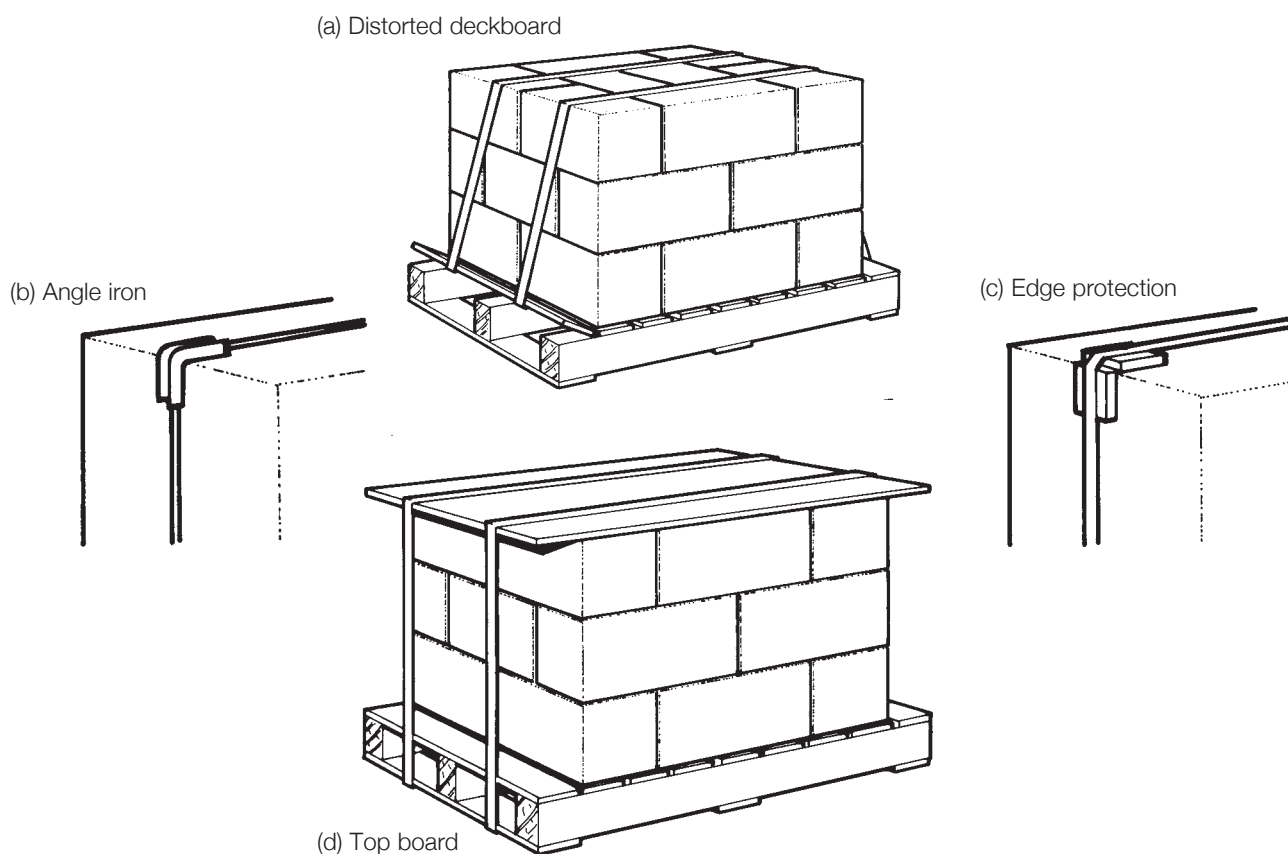
Be careful when using strapping to secure loads to pallets, as you can cause damage if you use too much tension and/or incorrect strap positions (see Figure 5).



**Figure 3** Any kind of sliding-and-dropping action should be avoided

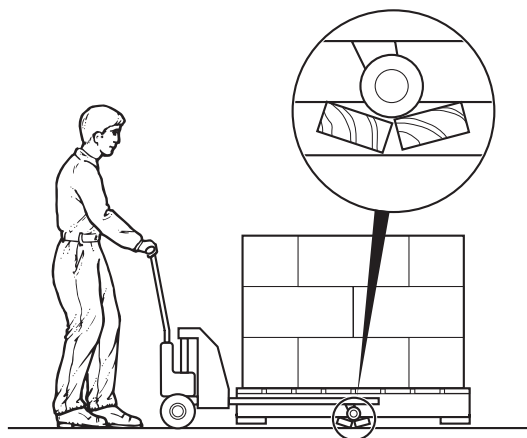


**Figure 4** Improvised manual handling – with, for example, the platform of a sack truck – can loosen deck boards



**Figure 5** Tight strapping of too small loads can distort deckboards, see (a) above. Angle iron (b), edge protection (c) or top boards (d) can improve load packaging

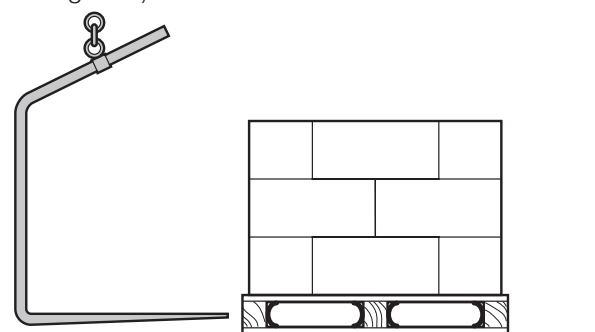
If pallet trucks are used, make sure that the small finger wheels do not damage the base boards (see Figure 6). Chamfered edges to the top of the base boards will assist entry of the pallet truck finger wheels. Use of pallets meeting base window requirements of BS ISO 6780<sup>3</sup> together with trucks meeting BS ISO 509<sup>9</sup> will normally avoid such damage.



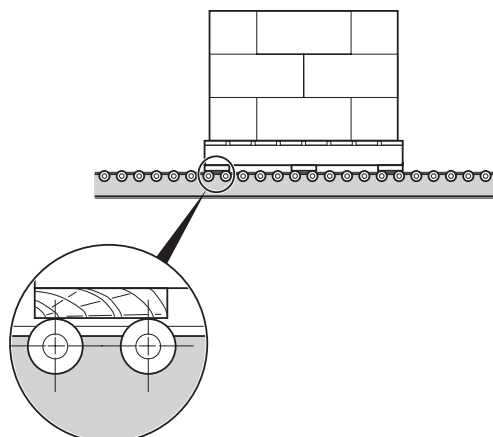
**Figure 6** Pallet truck fingers of unsuitable length can cause baseboard damage and can also be dangerous to workers

Pallets handled by a crane should only be lifted by suitable fork attachments (see Figure 7) or in the case of wing pallets, by bar slings with spreaders.

When pallets are moved by conveyor, always ensure that the conveyor roller spacing is less than the width of pallet deck members to avoid damage by jamming (see Figure 8).



**Figure 7** Handling of pallets by crane can generally be improved with the use of C-hook pallet fork attachments



**Figure 8** The spacing of pallet conveyor rollers should be less than that of pallet base members, otherwise jamming can occur



The forks of a handling device should extend into the pallet at least 75% of the dimension parallel to the forks. Only authorised and trained personnel should operate fork trucks – see *Rider-operated lift trucks. Operator training and safe use* (L117).<sup>10</sup> Forklift truck operators should receive instructions on the correct method of handling pallets. This should highlight that:

- the mast should be in the vertical position when entering and leaving a pallet (see Figure 9a, 9b);
- the forks should be spaced so that maximum support is given to the pallet when lifted (see Figure 10);
- the pallet should be housed against the heel of the forks;
- the forks should enter the pallet squarely;
- pallets should not be pulled or pushed along the ground or stacks be squared up by pushing one corner;
- loads should be carefully and gently placed on the stack below;
- pallets must never be used with a forklift truck as an access platform – see HSE Guidance Note PM28 *Working platforms (non-integrated) on forklift trucks*.<sup>11</sup>

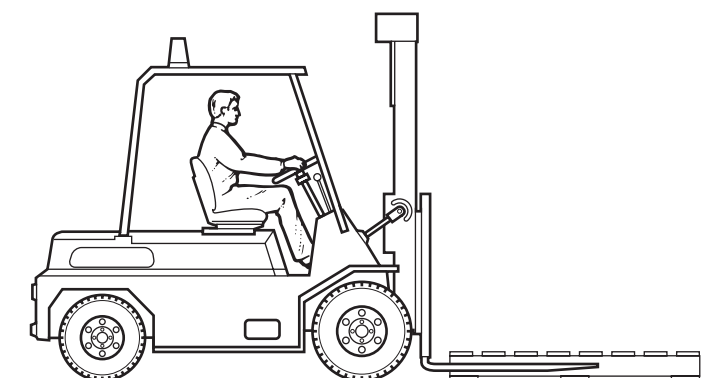


Figure 9(a) Correct procedure for entering a pallet

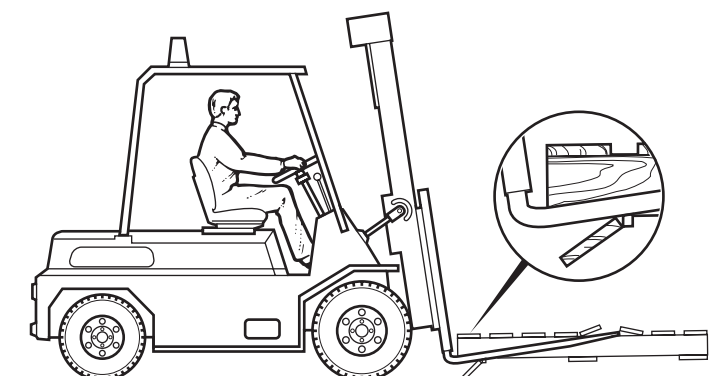
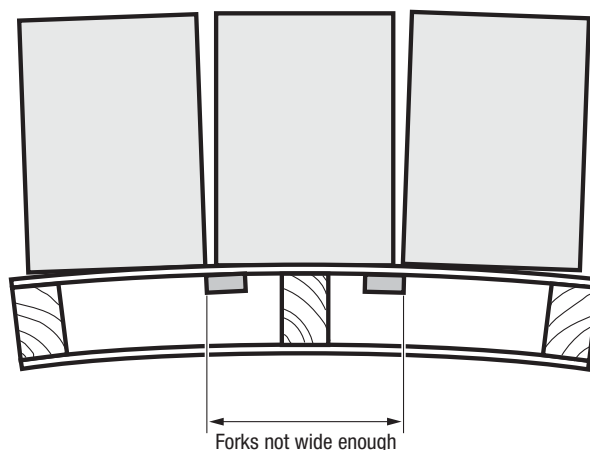
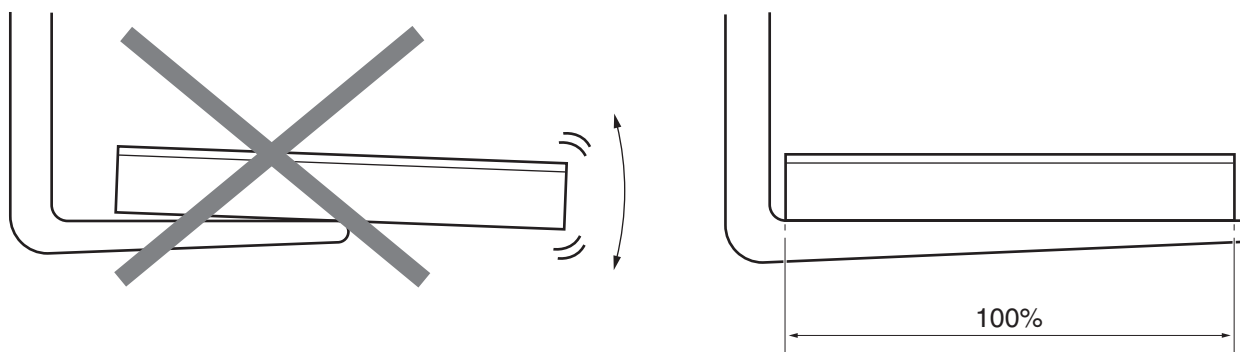


Figure 9(b) Wrong procedure as mast should be absolutely vertical. Mast should not be tilted backwards until forks have fully entered the pallet



**Figure 10** Optimum distance between forks should be known in relation to pallet size

When pallets are lifted within storage and retrieval machines, pay particular attention to the baseboard structural integrity. When pallets are lifted from below, by forks, or platens, these should support the full length of the pallet, ie 100% of the dimension parallel to the forks (see Figure 11).



**Figure 11** When lifted from below, forks should support the full length of the pallet

## Pallet inspection

The following checklist gives a guide for the basis of a periodic pallet inspection programme. This list should be extended to take account of any special local and environmental conditions.

It is vital that everyone concerned understands that the proper repair of a pallet restores it to its original specification. This will require the use of compatible materials of suitable quality, correct dimensions and appropriate fastening techniques, eg timber pallet nails should be supplied in accordance with BS ISO 12777-1.<sup>12</sup>

### Timber pallets (see Figure 12)

Here are some general points to consider, but for detailed information please refer to BS EN ISO 18613,<sup>8</sup> or quality standards published by the pallet owner or organisation responsible.

Check that:

- in four-way perimeter base pallets every base board is fastened at each end with two or more nails that appear to be of correct length and diameter with adequate edge distance;
- the stringer boards are made of sound timber and there aren't too many knots;
- the stringer boards are of equal thickness, as specified in the purchaser's specifications;
- the deck boards, stringer boards and base boards meet the required thickness and width of the purchaser's specifications;
- the deck boards are made of sound timber and there aren't too many knots;
- the base boards are not split at their fastened end;
- there are no damaged bearers or blocks;
- there are no projecting nails or nails pulled through deck boards;
- there are no edge splits in any board members;
- there are no loose joints permitting racking out of square (diamonding);
- the pallet is clean and free from contamination.

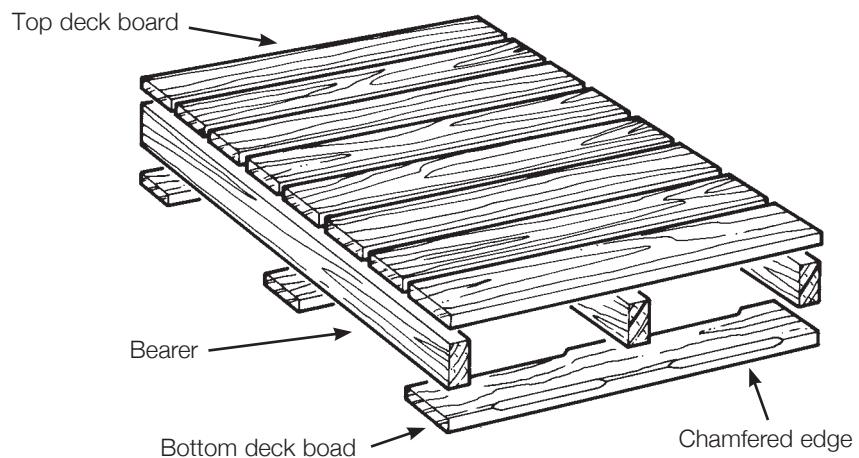


Figure 12(a) Four-way entry

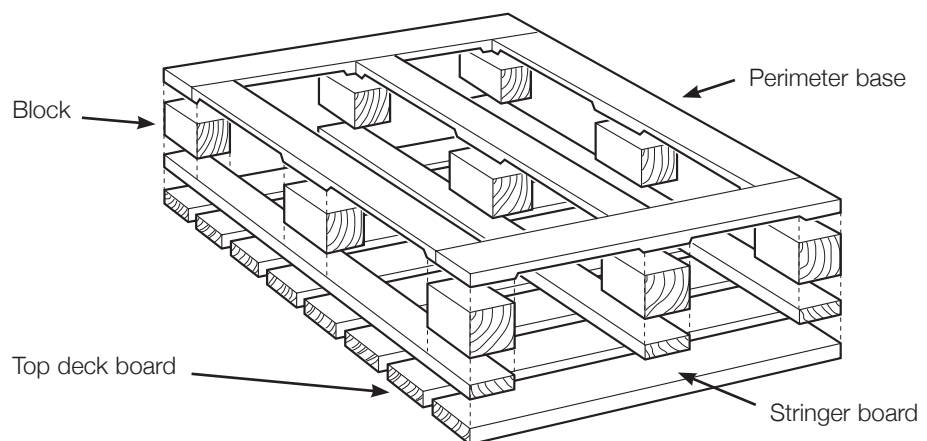


Figure 12(b) Four-way entry (underside view)

The following lists for plastic, pressed wood, corrugated cardboard and metal pallets provide examples of things to consider. However, you should seek further guidance from the pallet manufacturers.

### Plastic pallets (see Figure 13)

When used in cold temperatures and handled roughly, plastic pallets are susceptible to brittle fracture. Checks are therefore required to make sure they are free from cracks or other mechanical damage. Check that:

- the deck is free from damage due to excessive heat/cold and chemical spillage;
- the deck or base is not defective;
- the deck supports or bearers are not worn, cracked or permanently deformed;
- if the supports are hollow, they are free from trapped debris and damage;
- there is no degradation that has occurred due to ultraviolet light (sunlight) – if the pallets have become faded, get advice from the manufacturers about continuing to use them;
- the pallet does not show signs of white, dusty surface deposits. If it does, you should reject it;
- the pallet has not permanently distorted during use.

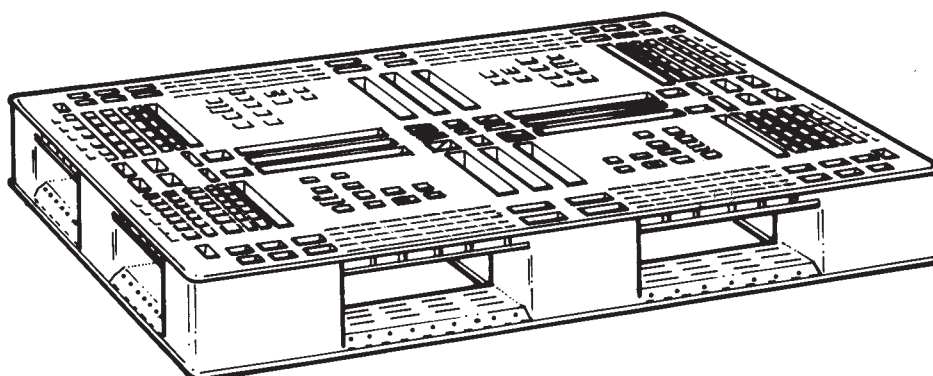


Figure 13 Plastic pallet

### Pressed wood pallets (see Figure 14)

Check that:

- the pallet is free from cracking, flaking and/or wear;
- there are no signs of water absorption, indicated by local swelling or blistering;
- the pallet has no damage from excessive heat/cold or chemical spillage;
- if the base supports are hollow, they are free from debris and damage and any drainage holes (if provided) are clear.

Pressed wood or chipboard pallets for external use should meet the moisture resistance requirements detailed in BS EN ISO 8611-2.<sup>5</sup>

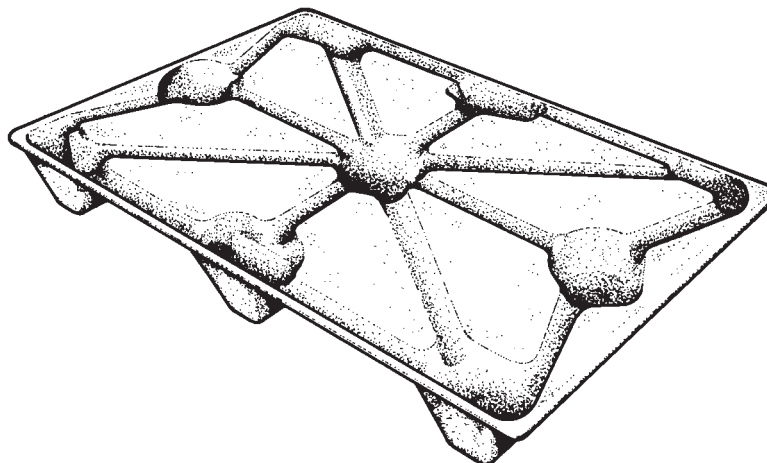


Figure 14 Pressed wood pallet

### Corrugated cardboard pallets (see Figure 15)

Check that:

- the pallet has no indentations;
- the deck has no damage from excessive heat/cold and chemical spillage;
- the pallet has no moisture damage;
- the deck or base is not defective;
- the base supports/bearers are not worn, torn, cracked or permanently deformed;
- if the supports are hollow, they are free from debris and damage;
- the pallet has not lost its rigidity;
- there are no loose joints visible.

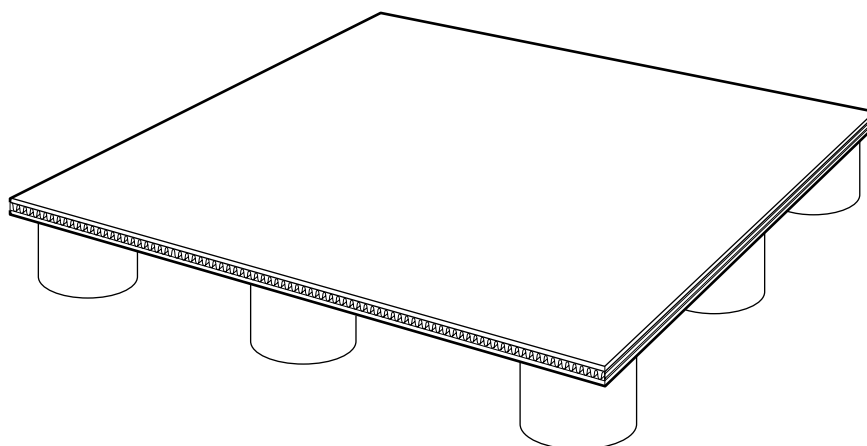


Figure 15 Corrugated cardboard pallet

## Metal pallets (see Figure16)

Check that:

- the pallet is free from corrosion and weld cracking;
- the deck has no damage due to chemical spillage;
- the deck or base is not worn;
- the base supports/bearers are not worn, cracked or permanently deformed;
- if the supports are hollow, they are free from debris and damage;
- the paint/protective finish is in a satisfactory condition;
- the pallet is not distorted.

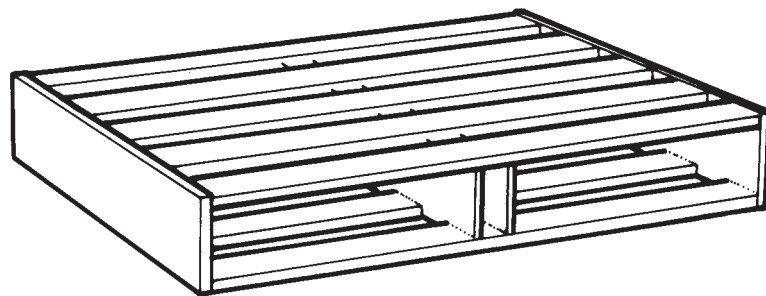


Figure 16 Metal pallet

## References

- 1 *Safe use of work equipment. Provision and Use of Work Equipment Regulations 1998. Approved Code of Practice and guidance L22* (Third edition) HSE Books 2008 ISBN 978 0 7176 6295 1 [www.hse.gov.uk/pubns/books/l22.htm](http://www.hse.gov.uk/pubns/books/l22.htm)
- 2 BS ISO 445: 2013 *Pallets for material handling. Vocabulary*
- 3 BS ISO 6780:2003 *Flat pallets for intercontinental materials handling. Principle dimensions and tolerances*
- 4 BS EN ISO 8611-1:2012 *Pallets for materials handling. Flat pallets. Test methods*
- 5 BS EN ISO 8611-2:2012 *Performance requirements and selection of tests*
- 6 BS EN ISO 8611-3:2012 *Maximum working loads*
- 7 *Workplace transport safety. An employers' guide HSG136* (Second edition) HSE Books 2005 ISBN 978 0 7176 6154 1 [www.hse.gov.uk/pubns/books/hsg136.htm](http://www.hse.gov.uk/pubns/books/hsg136.htm)
- 8 BS EN ISO 18613:2003 *Repair of flat wooden pallets*
- 9 BS ISO 509: 1996 *Pallet trucks. Principle dimensions*
- 10 *Rider-operated lift trucks. Operator training and safe use. Approved Code of Practice and guidance L117* (Third edition) HSE Books 2013 ISBN 978 0 7176 6441 2 [www.hse.gov.uk/pubns/books/l117.htm](http://www.hse.gov.uk/pubns/books/l117.htm)
- 11 *Working platforms (non-integrated) on forklift trucks* Guidance Note PM28 HSE 2013 (Fourth edition) [www.hse.gov.uk/pubns/pm28.htm](http://www.hse.gov.uk/pubns/pm28.htm)
- 12 BS EN ISO 12777-1:1996+A1:2008 *Methods of test for pallet joints. Determination of bending resistance of pallet nails, other dowel-type fasteners and staples*

## Further reading

HSE's risk management website: [www.hse.gov.uk/risk](http://www.hse.gov.uk/risk)

*Workplace health, safety and welfare. Workplace (Health, Safety and Welfare) Regulations 1992. Approved Code of Practice L24 (Second edition) HSE Books 2013 ISBN 978 0 7176 6583 9 [www.hse.gov.uk/pubns/books/l24.htm](http://www.hse.gov.uk/pubns/books/l24.htm)*

BS EN 12777-2:2000 *Methods of test for pallet joints. Determination of withdrawal and head pull-through resistance of pallet nails and staples*

BS EN 12777-3:2002 *Methods of test for pallet joints. Determination of strength of pallet joints*

## Further information

For information about health and safety, or to report inconsistencies or inaccuracies in this guidance, visit [www.hse.gov.uk](http://www.hse.gov.uk). You can view HSE guidance online and order priced publications from the website. HSE priced publications are also available from bookshops.

British Standards can be obtained in PDF or hard copy formats from BSI: <http://shop.bsigroup.com> or by contacting BSI Customer Services for hard copies only Tel: 020 8996 9001 email: [cservices@bsigroup.com](mailto:cservices@bsigroup.com).

This guidance is issued by the Health and Safety Executive. Following the guidance is not compulsory, unless specifically stated, and you are free to take other action. But if you do follow the guidance you will normally be doing enough to comply with the law. Health and safety inspectors seek to secure compliance with the law and may refer to this guidance.

This publication is available at [www.hse.gov.uk/pubns/pm15.htm](http://www.hse.gov.uk/pubns/pm15.htm).

© *Crown copyright* If you wish to reuse this information visit [www.hse.gov.uk/copyright.htm](http://www.hse.gov.uk/copyright.htm) for details. First published 10/14.